

K-50L-QG-75/R Mounting Instructions

Rev 2

- 1) The K-50L-QG-75/R can be mounted at various heights (Shown here with a .250" test fixture):
- 2) If the height of the spacer is (X) and the test fixture thickness is T the recommended height to the bottom of the test fixture (Z) can be found from $1.133'' - X - T = Z$.

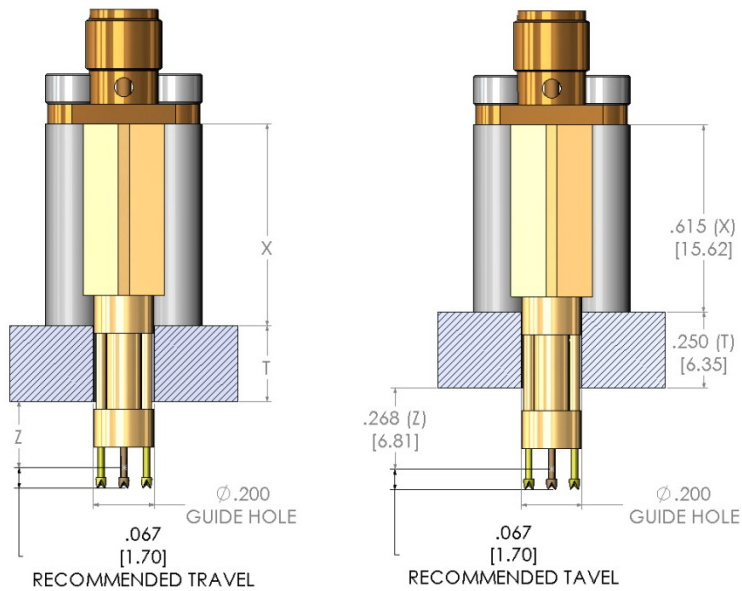

- 3) Drill THRU hole with a diameter of .200" (5.08mm) into test fixture. This hole is used to align the coax.

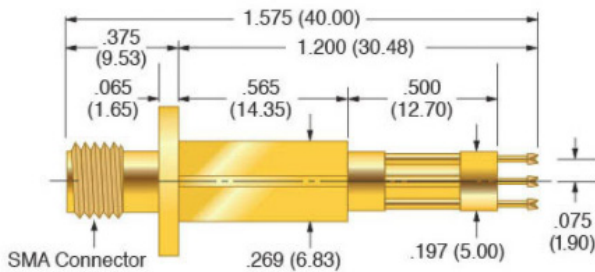

- 4) Drill mounting holes into test fixture with the pattern shown below:

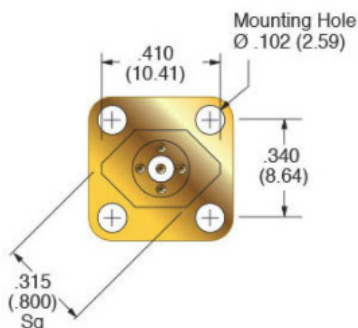

- 5) Mount with spacers and 2-56 (2.5mm) screws.